



# **Owner's Manual**

**Pelican PF3/PF6  
Premium Whole House Fluoride Filter**

© Copyright 2011 Enviro Water Solutions Inc. All rights reserved.

All information contained herein is the property of Pelican Water Systems. Pelican Water Systems makes no warranty of any kind with regard to this material, including, but not limited to, the implied warranties of merchantability and fitness for a particular purpose. Pelican Water Systems shall not be liable for technical or editorial errors or omissions contained herein or for incidental or consequential damages in connection with the furnishing, performance, or use of this material. The information is provided "as is" without warranty of any kind and is subject to change without notice. This document contains proprietary information which is protected by copyright. No part of this document may be photocopied, reproduced, or translated into another language without the prior written consent of Pelican Water Systems. Pelican Water Systems is an Enviro Water Solutions, Inc. company.

## Table of Contents

|   |           |
|---|-----------|
| <b>Table of Contents</b> .....                      | <b>3</b>  |
| <b>Product Operation and Specifications</b> .....   | <b>4</b>  |
| <b>Important Information</b> .....                  | <b>4</b>  |
| <b>Complete Parts List</b> .....                    | <b>5</b>  |
| <b>Installation Overview</b> .....                  | <b>6</b>  |
| <b>Pre-Installation</b> .....                       | <b>6</b>  |
| Bypass Valve Installation .....                     | 6         |
| Fluoride Filter Soak .....                          | 7         |
| Fluoride Filter Wash .....                          | 8         |
| <b>Installation</b> .....                           | <b>9</b>  |
| Pre-Filter Assembly .....                           | 9         |
| Pre-Filter Installation .....                       | 9         |
| Whole House Fluoride Filter Tank Installation ..... | 10        |
| <b>Complete the Installation</b> .....              | <b>11</b> |
| Adding the Pelican Logo Sticker: .....              | 11        |
| <b>Care and Cleaning</b> .....                      | <b>12</b> |
| Premium Whole House Fluoride Filter .....           | 12        |
| Sediment Filter .....                               | 12        |
| Replacing the Sediment Filter .....                 | 12        |
| <b>Troubleshooting</b> .....                        | <b>13</b> |
| <b>Warranty</b> .....                               | <b>14</b> |
| Warranty Registration Form .....                    | 15        |
| <b>Product Certifications</b> .....                 | <b>16</b> |

## Product Operation and Specifications

| Specification Description | PF3              | PF6    |
|---------------------------|------------------|--------|
| Max Flow Rate             | 10 GPM           | 15 GPM |
| Minimum Working Pressure  | 25 PSI           |        |
| Maximum Working Pressure  | 80 PSI           |        |
| Maximum Vacuum            | 5 inch/127 mm Hg |        |
| Operating Temperatures    | 36°F – 120°F     |        |
| pH Range                  | 6 – 11           |        |

### Important Information

- Read these instructions carefully and determine the location of all system components before beginning installation.
- Check all applicable plumbing, building, and electrical codes for installation compliance.
- Install the system on the main water supply.
- Systems that contain electronic components cannot be installed outside in uncovered areas.

#### **⚠ WARNING:**

If this or any other system is installed in a metal (conductive) plumbing system, i.e. copper or galvanized metal, the plastic components of the system will interrupt the continuity of the plumbing system. As a result any errant electricity from improperly grounded appliances downstream or potential galvanic activity in the plumbing system can no longer ground through contiguous metal plumbing. Older homes may have been built in accordance with building codes from decades ago, some of which actually encouraged the grounding of electrical appliances through the plumbing system. Consequently, the installation of a bypass consisting of the same material as the existing plumbing, or a grounded "jumper wire" bridging the equipment and re-establishing the contiguous conductive nature of the plumbing system must be installed prior to your systems use.





#### **⚠ CAUTION:**

When adding a filtration/softening system to homes/buildings supplied by well water, the system should be installed following the pressure tank. **DO NOT USE this system for pneumatic or hydro pneumatic applications. If you are using a booster pump, then install this system following the booster pump.** If you have questions, please call customer service.

## Complete Parts List

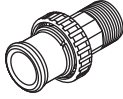
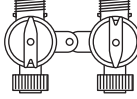
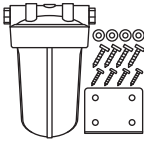
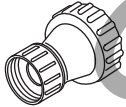
**Note:** Pelican supplies the parts below to accommodate a variety of water supply lines.

**Table 1: Parts List**

| Part  | Description   | Qty. | Part   | Description  | Qty. |
|---|---|------|--|--|------|
|    | <b>1" Plastic Male NPT Assembly:</b><br>V3007-04 WS1 Fitting 1" Plastic Male NPT Assembly (2): O-Rings (2), Split Rings (2), and Connectors (2) | 1    |   | <b>Bypass Valve:</b><br>In/Out Bypass Valve with Red Arrow Handles | 1    |
|    | <b>Pre-Filter System:</b><br>PP5 Big Blue Pre-Filter Housing, Mounting Bracket, Phillips Head Screws (4), Bolt Head Screws (4), and Washers (4) | 1    |   | <b>Hose Bib Assembly</b>   | 1    |
|   | <b>Sediment Filter:</b><br>PC40-1 5 Micron Poly-Spun Sediment Filter  | 1    |  | <b>Pelican Whole House Fluoride Filter</b>                         | 1    |
|  | <b>Pre-Filter Wrench</b>  | 1    |  |  |      |

**Note:** Drawings are not to scale.

Additional fittings will be needed to adapt to your plumbing.

## Installation Overview

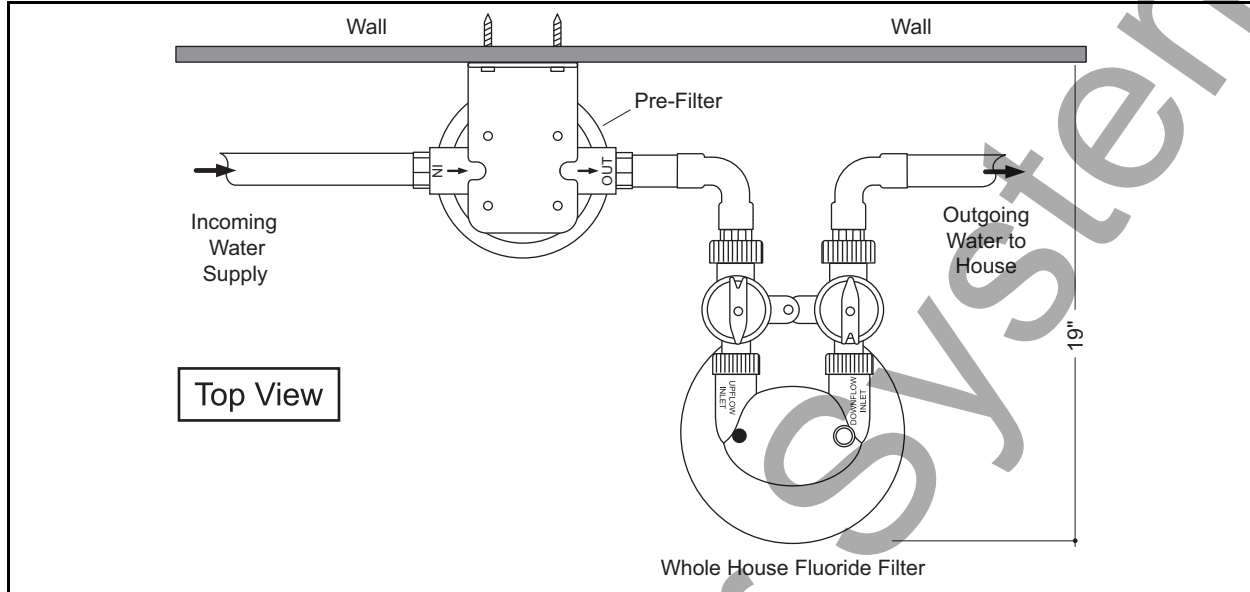

Figure 1

## Pre-Installation

### Bypass Valve Installation

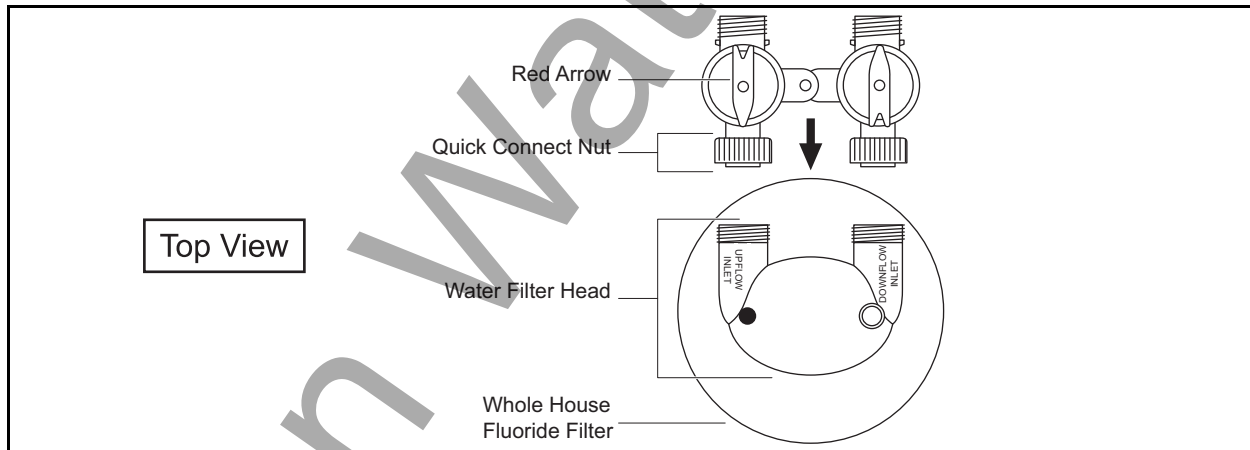

Figure 2

The Bypass Valve comes pre-assembled and ready to install with the O-Rings, Split Rings, and Quick Connect Nuts. Push the Bypass Valve into the head of the Whole House Fluoride Filter with the unthreaded ends oriented toward the tanks and hand-tighten the Quick Connect Nuts.

### Notice:

The bypass valve(s) included with this system are designed for multiple Pelican water systems. This may result in the arrows on the bypass valve(s) pointing differently than shown. If the arrows on your bypass valve(s) do not match the diagram, remove the red arrows by pulling them straight up, turn them 180° to match the drawing, and push them back down onto the stem.

## Fluoride Filter Soak

### !!IMPORTANT!

Your system will not be ready for use for a minimum of 48 hours while the Fluoride Filter Soak process takes place. Please plan your installation accordingly.



### Notice:

Water will flow out of the downflow inlet side of the Bypass Valve during this process. Be sure you perform this series of steps in a location suitable for water flow.

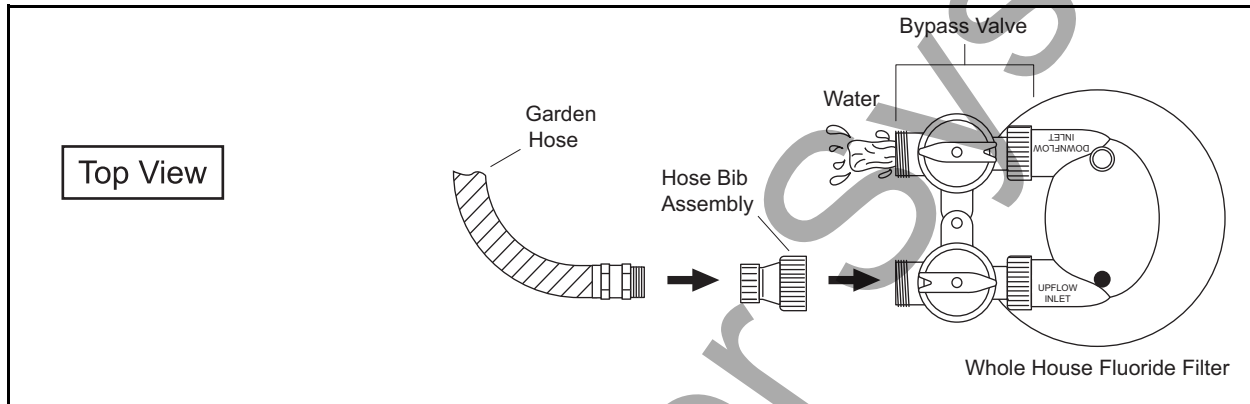

Figure 3

1. Attach a garden hose to the Hose Bib Assembly.
2. Connect the Hose Bib Assembly to the upflow inlet side of the Bypass Valve and hand tighten.
3. Fill the Pelican Whole House Fluoride Filter Tank full until water comes out of downflow inlet side of the Bypass Valve.
4. Turn the water off.
5. Remove the garden hose from the Hose Bib Assembly. Do not remove the fitting.
6. Allow the carbon tank to soak for at least 48 hours prior to tank installation.

## Fluoride Filter Wash

### !!IMPORTANT!!

Do not perform the Fluoride Filter Wash until the Fluoride Filter Soak process is complete.



### Notice:

Water will flow out of the downflow inlet side of the Bypass Valve during this process. Be sure you perform this series of steps in a location suitable for water flow.

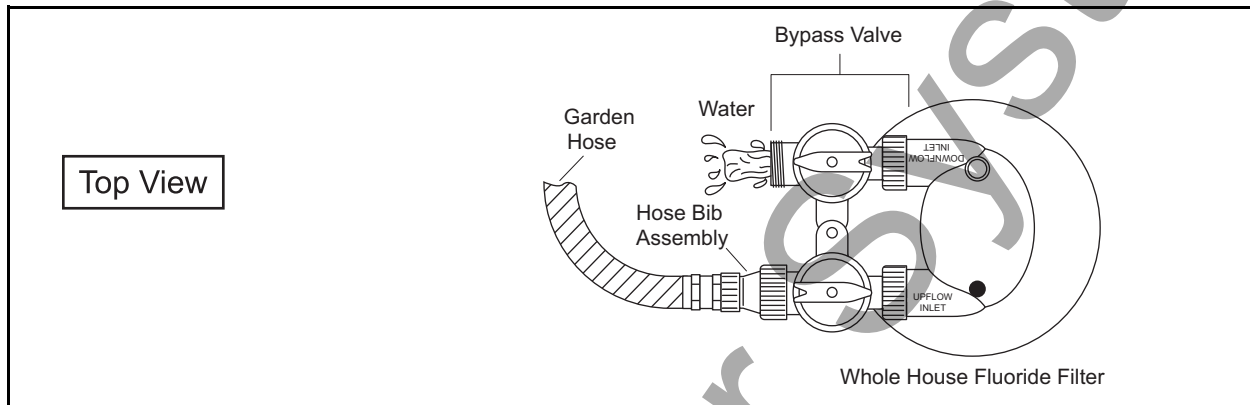

Figure 4

1. Reattach the garden hose to the Hose Bib Assembly.
2. Slowly turn on the water 1/4 turn for this entire process.
3. Run water through the upflow inlet side of the Bypass Valve for 15-30 minutes or until the water discharging from the downflow inlet side of the Bypass Valve runs clear.
4. Turn off the water.
5. Remove the Hose Bib Assembly from the upflow inlet side and attach it to the downflow inlet side of the Bypass Valve.
6. Run the water through the downflow inlet side for 1 minute or until water runs clear.
7. Turn off the water.
8. Remove the Hose Bib Assembly from the Bypass Valve and disconnect the garden hose.

**Note:** Please save the Hose Bib Assembly as this will be used in the future for the carbon exchange.

## Installation

### Pre-Filter Assembly

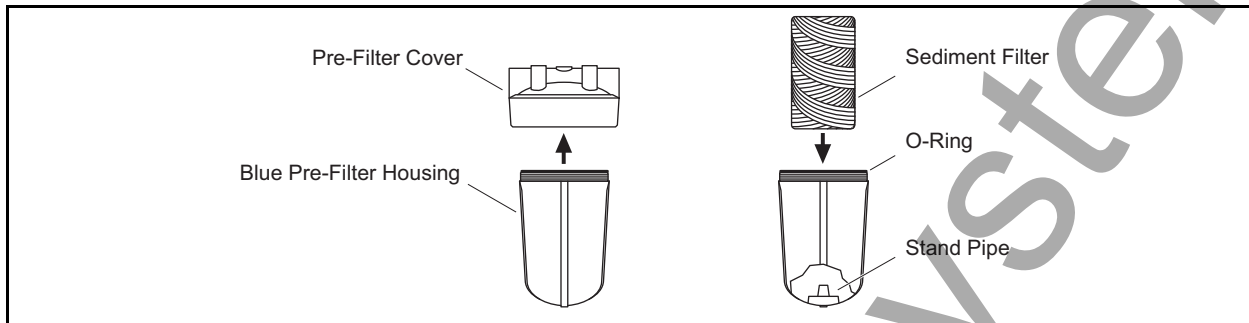

Figure 5

1. Unscrew the cover from the Blue Pre-Filter Housing.
2. Remove the plastic covering from the Sediment Filter.
3. Place the Sediment Filter onto the Stand Pipe in the Blue Pre-Filter Housing.
4. Screw the cover onto the Blue Pre-Filter Housing until hand-tight.

### Pre-Filter Installation

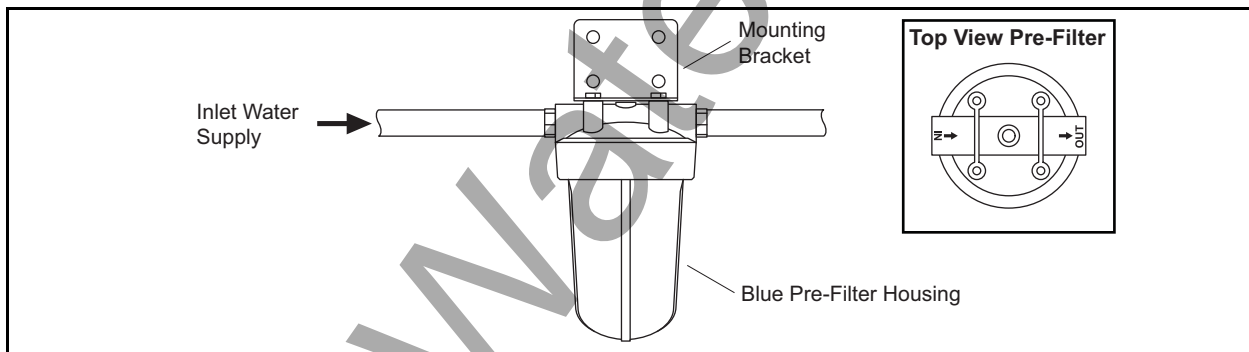

Figure 6

1. Shut off the water.
2. Attach the Mounting Bracket to the wall using the supplied Phillips Head Screws and Washers.
3. Attach the Pre-Filter System to the Mounting Bracket using the supplied Bolt Head Screws.
4. Lube the o-ring with clean silicone grease before attaching the cover onto the housing.
5. Tighten the Blue Pre-Filter Housing using the supplied Pre-Filter Wrench (counter clockwise).
6. Determine the size of your inlet water supply line. PVC Reducers may be needed to fit the 1" Pre-Filter System.



#### Notice:

The Pre-Filter Housing comes with a 1" threaded female inlet/outlet and will require additional fittings to adapt to your plumbing. A shut-off valve is recommended prior to the Pre-Filter System.

## Whole House Fluoride Filter Tank Installation

1. Level the Pelican Whole House Fluoride Filter



### Notice:

If the tank is not level, lift the tank straight up 6 inches and tap it on the ground until the tank stands vertical. The bottom of the tank is round and the boot allows the tank to stand upright.

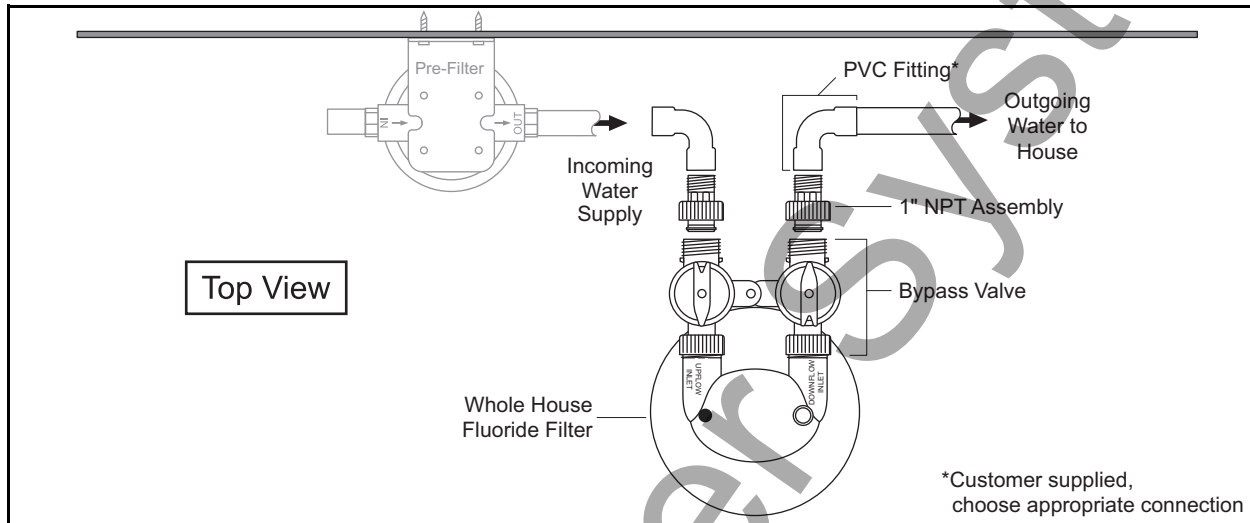

Figure 7

2. Determine the size and material of your incoming water supply line from the Pre-Filter System and choose the appropriate plumbing required to adapt to the 1" Male NPT Assembly.

### CAUTION:

Do not over-tighten any of the fittings during installation.

### Table 2: Bypass Valve Fittings

**Note:** The fitting below is designed with a 1/4" give to allow for proper pipe alignment. It will not leak and is intended to have some flexibility.

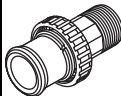
| Part  | Description   | Qty.  |
|---|---|-------|
|  | <b>1" Plastic Male NPT Assembly:</b><br>V3007-04 WS1 Fitting 1" Plastic Male NPT Assembly (2); O-Rings (2), Split Rings (2), and Connectors (2) | 1 bag |

3. Install the fitting onto the upflow and downflow inlet sides of the Bypass Valve. Follow the diagram supplied with the fitting.
4. Connect the incoming water supply from the Pre-Filter System to the fitting on the upflow inlet side of the Bypass Valve.
5. Connect the outgoing water supply to the downflow inlet side of the Bypass Valve.

## Complete the Installation

1. Turn on the main water supply.
2. Check for leaks.
3. Peel off the protective plastic wrap from the chrome tank jackets.

**⚠ CAUTION:**

Avoid high flow rates such as bathtub, utility sinks, hose bibs, multi-headed showers, body sprayers, or anything that is considered high flow for the first 72 hours to avoid flow restrictions caused by carbon blockage of the top basket inside the fluoride filter.

**⚠ CAUTION:**

Carbon dust may be released into the water lines of the house/building during the first few days of water use after fluoride filter installation. The carbon dust is harmless, but may give the water a gray appearance that should diminish within a week or 10 days depending on water use.

### Adding the Pelican Logo Sticker:

1. Peel back plastic to remove it from the tank.
2. Place sticker in the desired location on the tank.

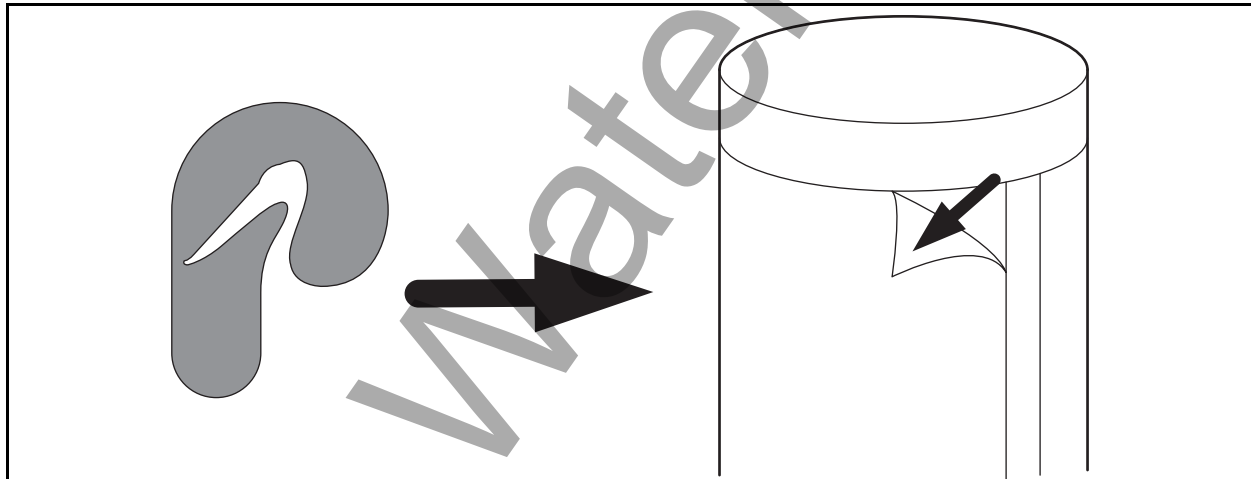

## Care and Cleaning

### Premium Whole House Fluoride Filter

Your Pelican PF3/PF6 Premium Whole House Fluoride Filter requires care and cleaning after a period of 3 years. Replacement media and instructions can be ordered on-line at [www.pelicanwater.com](http://www.pelicanwater.com) or by calling 877-842-1635.

### Sediment Filter

It is recommended that the Sediment Filter be replaced every 6-9 months depending on the amount of sediment present in the water supply. If the system has been working properly and the pressure is slowing, it may be time to change the Sediment Filter. Check the Sediment Filter and replace if necessary.

### Replacing the Sediment Filter

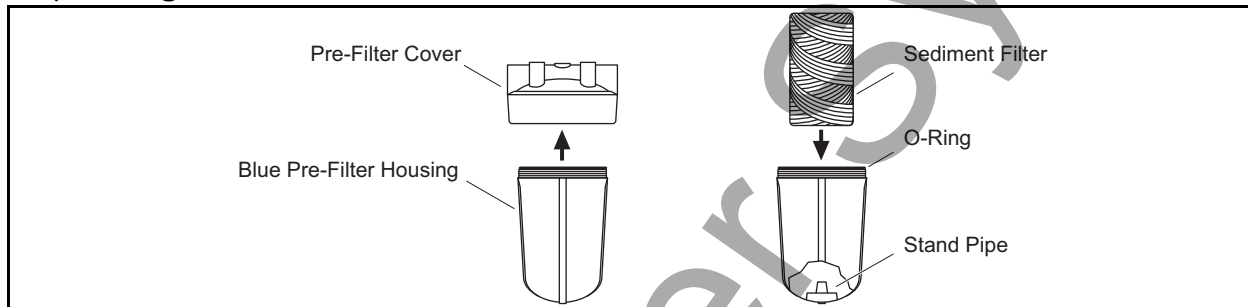

Figure 8

1. Turn off the main water supply to the Pre-Filter System and bypass all tanks.
2. Run a faucet (cold water) inside the house to relieve the pressure.
3. Unscrew the Blue Pre-Filter Housing clockwise using the supplied Pre-Filter Wrench.
4. Remove the existing Sediment Filter and discard.
5. Remove the O-Ring and wipe the groove and O-Ring clean. Lubricate the O-Ring with a coating of clean silicone grease. Replace O-Ring and press the O-Ring down into the groove with two fingers.

**Note:** This step is important to ensure the proper filter seal. Make sure the O-Ring is seated level in the groove. If the O-Ring appears damaged, stretched, or crimped it should be replaced at this time.

6. Place a new Sediment Filter onto the Stand Pipe in the Blue Pre-Filter Housing.
7. Screw the Blue Pre-Filter Housing onto the Pre-Filter Cover.
8. Turn on main water supply slowly to allow the Pre-Filter System to fill with water and put tanks back in service, out of bypass.
9. Check for leaks.

## Troubleshooting

| Problem  | Solution  |
|--|---|
| Water leaking at the top of the tank around the head.  | You may need to turn the head to tighten it. The tank head is pre-installed hand-tight, do not overtighten the head (just turn it snug).  |
| The tank leans to one side or is not level.  | If the tank is not level, lift the tank straight up 6 inches and tap it on the ground until the tank stands vertical. The bottom of the tank is round and the boot allows the tank to stand upright.  |
| <p>The diagrams illustrate the process of leveling the tank. The top row shows an unlevel tank with a curved boot. The middle diagram shows the tank being lifted 6 inches. The right diagram shows the tank being tapped on the ground. The bottom row shows an unlevel tank with a curved boot. The middle diagram shows the tank being lifted 6 inches. The right diagram shows the tank being tapped on the ground, resulting in a level tank and an unlevel boot.</p> |   |
| Water pressure is slowing.   | It is recommended that the Sediment Filter be replaced every 6-9 months depending on the amount of sediment present in the water supply. If the system has been working properly and the pressure is slowing, it may be time to change the Sediment Filter. Check the Sediment Filter and replace if necessary.   |
| Water appears grey or cloudy.  | Water may appear grey or cloudy for the first seven to ten days after installation due to extra carbon dust.  |
| Water pressure is slowing immediately after installation.  | High flow rates such as bathtubs, utility sinks, hose bibs, multi-headed showers, body sprayers, or anything that is considered high flow for the first 72 hours should be avoided. If you suspect a carbon blockage of the top basket due to a high-flow situation within the first 72 hours of installation, turn off any running water for at least 10 minutes. This will clear the blockage and you can resume using water at low or normal flow rates. |

## Warranty

### Pelicans Limited Lifetime Warranty

Pelican Water ("Pelican") warrants to the end user ("customer") that its tanks (13" & smaller), valves, in/out non-electric heads, bypass's, fittings and housings ("Covered Items") will be free from defects in material and workmanship under normal use and service for the life of the system\*\*.

### Limitations and Responsibilities

Pelican's obligation to the customer under these warranties shall be limited, at its option, to replacement or repair of Covered Items by these warranties, labor is not covered. Prior to return or repair of Covered Items, the customer must obtain a return goods authorization number from Pelican and at Pelicans option, return the Covered Items freight prepaid. Any Covered Item repaired or replaced under these warranties will be returned prepaid standard freight to the original point of shipment. Expedited freight options are available at customer expense.

No warranty is made with respect to defects or damaged due to neglect, misuse, alterations, accident, misapplication, physical damage, or damaged caused by fire, acts of God, or freezing. These warranties apply only to the original registered owner so long as the owner owns the home in which the unit was originally installed. Customer must register their system with Pelican within 90 days of purchase\* in order to obtain a warranty. Warranty will discontinue after the unit is removed from the location where it was originally installed. Warranty begins on the date of delivery of product to the customer. Improper maintenance of system (i.e. not replacing filters or media) on time will be considered "neglect". Installation of any system on water conditions outside of or beyond the recommended specs of any system voids any warranty.

Pelican gives this warranty to the customer in lieu of all other warranties, express or implied, including without limitation any implied warranties of merchantability or fitness for a particular purpose or treatment of certain water and hereby expressly disclaims all other such warranties. Pelican's liability hereunder shall not exceed the cost of the product. Under no circumstances will Pelican be liable for any incidental or consequential damages or for any other loss, damage or expense of any kind, including loss of use, arising in connection with the installation or use or inability to use the Covered Items or any water treatment system the Covered Items are incorporated into. These warranties are governed by the laws of the state of Florida and may change at any time without notice.

\*Failure by California and Quebec residents to complete the product registration form does not diminish their warranty rights.

\*\*For all orders placed on or after June 3rd, 2011.

## Warranty Registration Form

Send in this Warranty Registration Form to validate your warranty or visit [www.PelicanWater.com](http://www.PelicanWater.com) to complete warranty registration form online.

### Pelican Warranty Registration Form

|                             |            |        |
|-----------------------------|------------|--------|
| Date Item(s) were Received: | Order ID#: | Model: |
| _____                       | _____      | _____  |
| Dealer Purchased From:      |            |        |
| _____                       |            |        |
| Model/Serial Number:        |            |        |
| _____                       |            |        |
| Name:                       | _____      |        |
| Address:                    | _____      |        |
| City:                       | State:     | Zip:   |
| _____                       | _____      | _____  |

#### Send To:

Pelican Water Systems  
3060 Performance Circle, Suite 2  
DeLand, FL 32724  
Phone: 1-(877) 842-1635

#### Plumber's Information (optional)

We like to recommend good plumbers throughout the USA and if you were happy with your installer please give us their information so we can pass it on as a courtesy. Thank you for your time.



Name of Plumbing Company used to install system: \_\_\_\_\_

Phone #: (\_\_\_\_) - \_\_\_\_\_ of the Plumbing installer

**!!IMPORTANT!**

Do not use where water is microbiologically unsafe or with water of unknown quality without proper disinfection before or after the filter/softener system.

## Product Certifications

|   |  |
|---|--|
|  | <b>Pelican 5 Micron Pre-Filter System</b> – NSF/ANSI Certified Standard 42 for material and structural integrity requirements              |
|  | <b>Clack V3007-xx Bypass Fittings</b> – WWQA Gold Seal Certified to NSF/ANSI Standard 44 for material safety and structural integrity only |
|  | <b>U.S. Green Building Council</b>   |