



Owner's Manual

10-micron Hot Water Post-Filter System

© Copyright 2011 Enviro Water Solutions, Inc.® All rights reserved.

All information contained herein is the property of Pelican Water Technologies. Pelican Water Technologies makes no warranty of any kind with regard to this material, including, but not limited to, the implied warranties of merchantability and fitness for a particular purpose. Pelican Water Technologies shall not be liable for technical or editorial errors or omissions contained herein or for incidental or consequential damages in connection with the furnishing, performance, or use of this material. The information is provided "as is" without warranty of any kind and is subject to change without notice. This document contains proprietary information which is protected by copyright. No part of this document may be photocopied, reproduced, or translated into another language without the prior written consent of Pelican Water Technologies. Pelican Water Technologies is an Enviro Water Solutions, Inc. company.

Table of Contents

Table of Contents	3
Product Operation and Specifications	4
Important Information	4
Complete Parts List	5
Installation Overview	6
Assembly	7
Installation	8
Complete the Installation	8
Care and Cleaning	9
10-micron Filter	9
Replacing the 10-micron Filter	9
Warranty	11
Warranty Registration Form	13

Product Operation and Specifications

Specification Description	10-micron Hot Water Post-Filter System
Rated Service Flow	15 gpm
Minimum Working Pressure	30 psi
Maximum Working Pressure	125 psi
Maximum Vacuum	n/a
Operating Temperatures	40 - 160° F
pH Range	6 - 11



Important Information

- Read these instructions carefully and determine the location of all system components before beginning installation.
- Check all applicable plumbing, building, and electrical codes for installation compliance.

Complete Parts List

Note: Pelican supplies the parts below to accommodate a variety of water supply lines.

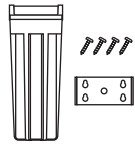
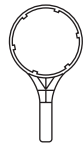
Table 1: Parts List

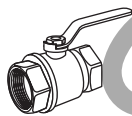
Part	Description	Qty.	Part	Description	Qty.
	10-micron Hot Water Post-Filter System: Housing, Housing Cover, Mounting Bracket, Phillips Head Screws (4)	1		Filter Wrench	1
	10-micron Filter	1		Brass Shut-Off Valve	1

Note: Drawings are not to scale.

Additional fittings may be needed to adapt to your plumbing.

Installation Overview

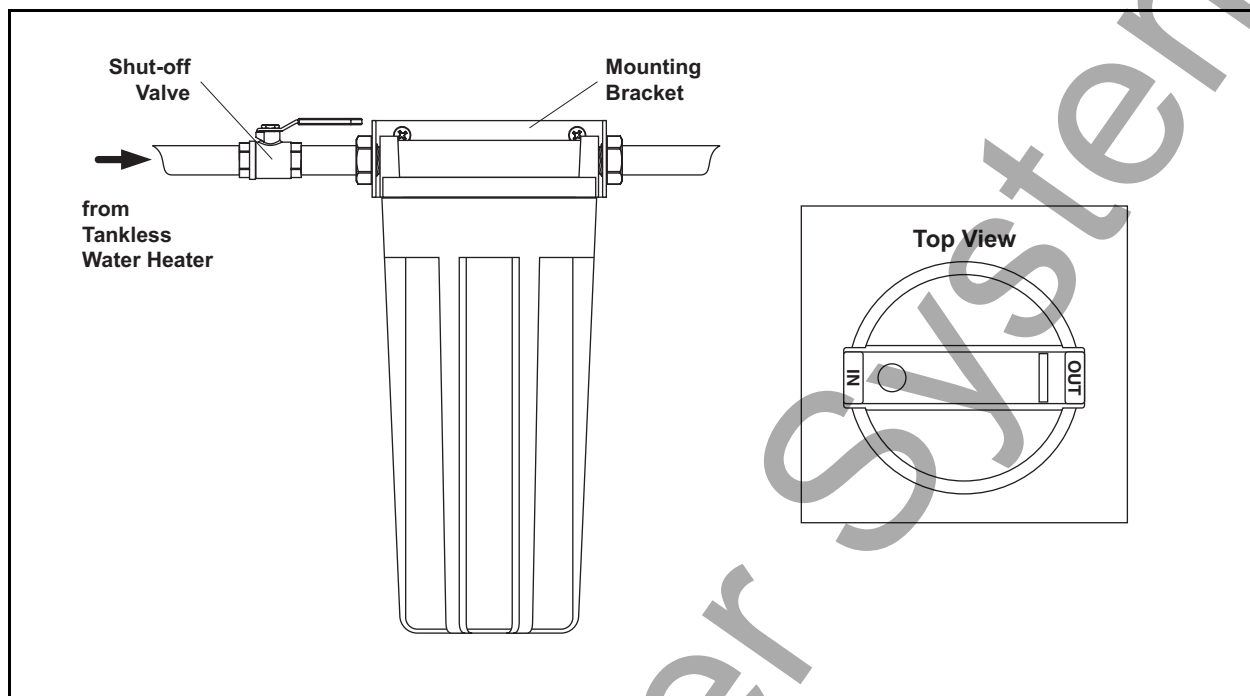

Figure 1

Assembly

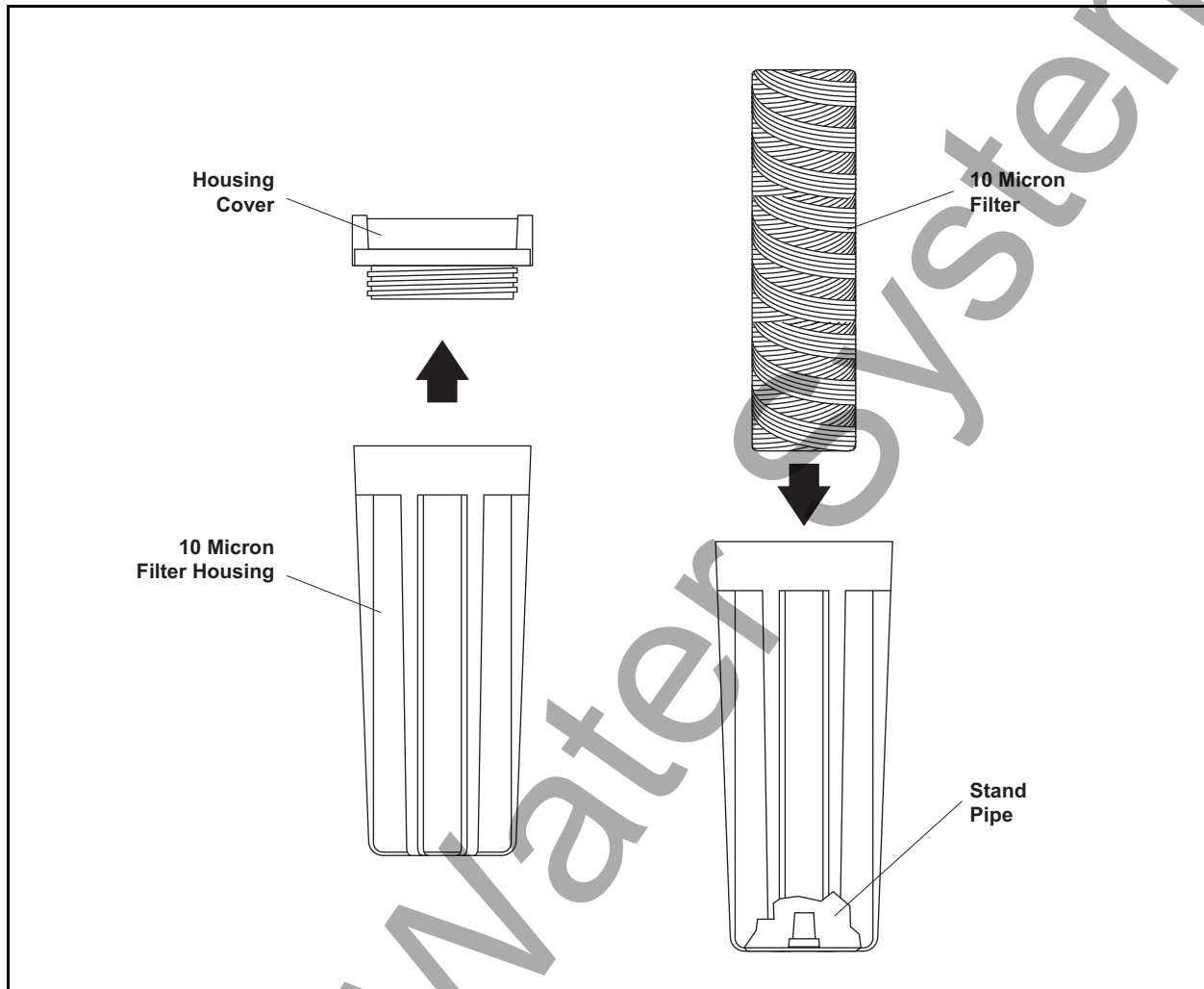

Figure 2

1. Unscrew the cover from the Filter Housing.
2. Place the 10-micron filter onto the Stand Pipe in the Filter Housing.
3. Screw the cover onto the Filter Housing until hand-tight.

Installation

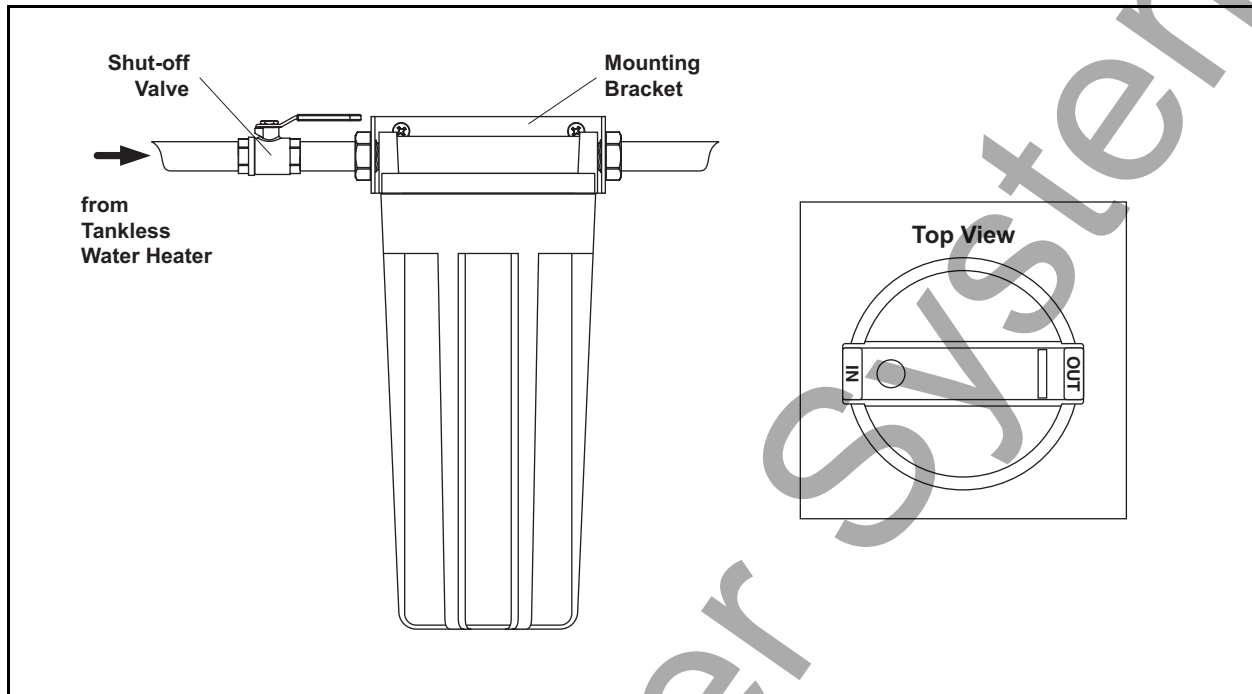

Figure 3

1. Shut off the main water supply.
2. Attach the Mounting Bracket to the wall using the supplied Phillips Head Screws.
3. Determine the size of your inlet water supply line from the Tankless Water Heater. Additional fittings may be required to adapt to your plumbing.
4. Attach the brass shut-off valve to the inlet water supply line prior to the Post-Filter System.
5. Thread the inlet water supply line through the hole on the inlet side of the mounting bracket and attach to the Filter Housing Cover inlet hand-tight.
6. Thread the outlet water supply line through the hole on the outlet side of the mounting bracket and attach to the Filter Housing Cover outlet hand-tight.
7. Tighten the Filter Housing using the supplied Filter Wrench (counter clockwise).

Note: Do not over-tighten any of the fittings during installation. All fittings should be hand-tight.

Complete the Installation

1. Turn on the main water supply.
2. Check for leaks.

Care and Cleaning

10-micron Filter

It is recommended that the 10-micron filter be replaced every 12 months.

Replacing the 10-micron Filter

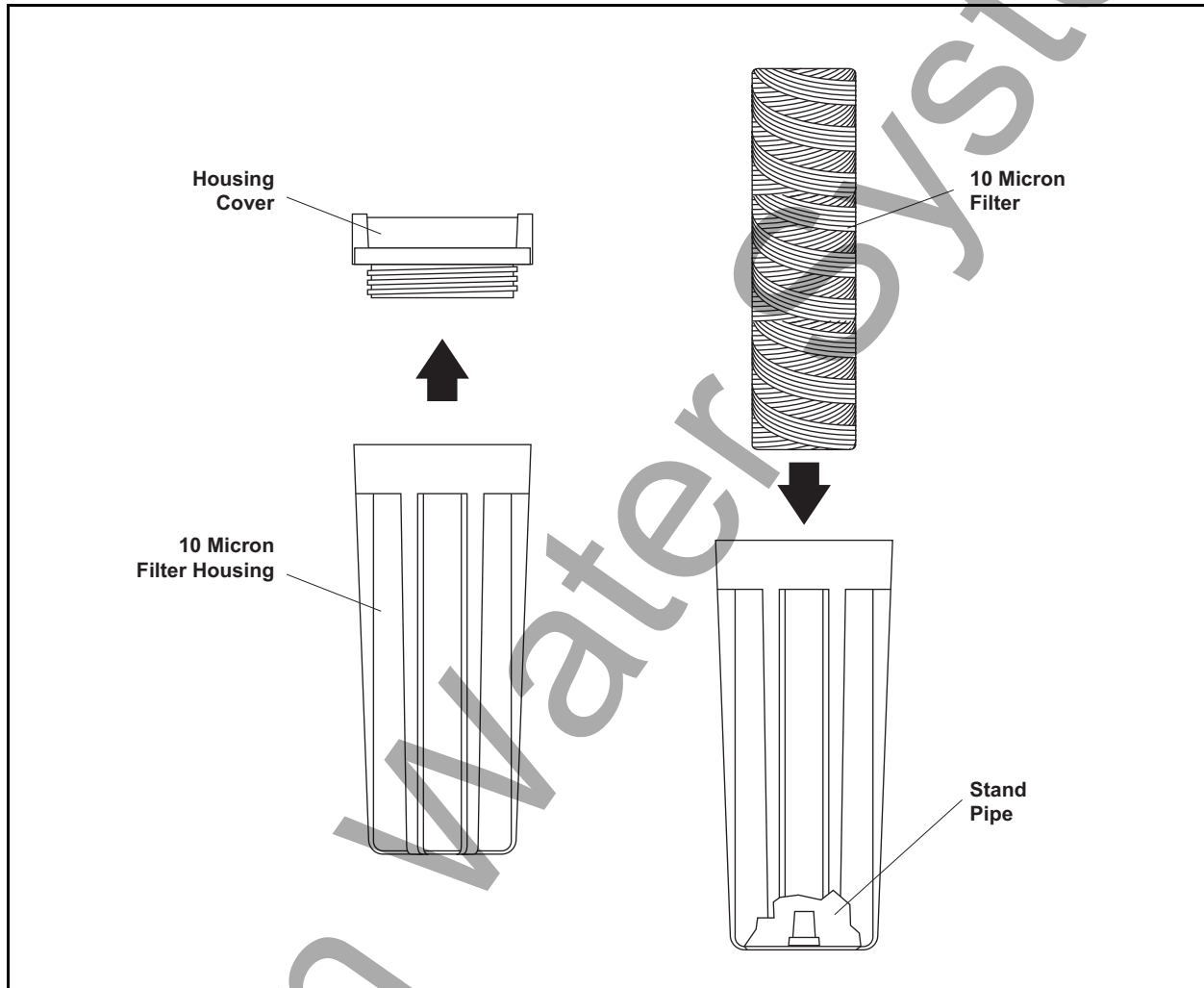

Figure 4

1. Turn off the water supply to the 10-micron Hot Water Post-Filter System.
2. Run the faucet (hot water) connected to the system to relieve the pressure.
3. Unscrew the Filter Housing clockwise using the supplied Filter Wrench.
4. Remove the existing 10-micron filter and discard.

5. Remove the O-Ring and wipe the groove and O-Ring clean. Lubricate the O-Ring with a coating of clean silicone grease. Replace O-Ring and press the O-Ring down into the groove with two fingers.

Note: This step is important to ensure the proper filter seal. Make sure the O-Ring is seated level in the groove. If the O-Ring appears damaged, stretched, or crimped it should be replaced at this time.

6. Place a new 10-micron filter onto the Stand Pipe in the Filter Housing.
7. Screw the Filter Housing onto the Housing Cover until hand-tight.
8. Turn on water supply slowly to allow the Post-Filter System to fill with water.
9. Check for leaks.

Warranty

Pelican's Limited Lifetime Warranty

Pelican Water ("Pelican") warrants to the end user ("customer") that its tanks (13" & smaller), valves, in/out non-electric heads, bypass's, fittings and housings ("Covered Items") will be free from defects in material and workmanship under normal use and service for the life of the system**.

Pelican 5 Year Limited Warranty

Pelican Water ("Pelican") warrants to the end user ("customer") that its retention tanks and solid-state electronic heads ("Covered Items") will be free from defects in material and workmanship under normal use and service for a period of 5 years.

Pelican 2 Year Limited Warranty

Pelican Water ("Pelican") warrants to the end user ("customer") that its metering pump motor ("Covered Items") will be free from defects in material and workmanship under normal use and service for a period of 2 years.

Pelican 1 Year Limited Warranty

Pelican Water ("Pelican") warrants to the end user ("customer") that its metering pump tubing, RO Systems and flow control switches ("Covered Items") will be free from defects in material and workmanship under normal use and service for a period of 1 year.

Limitations and Responsibilities

Pelican's obligation to the customer under these warranties shall be limited, at its option, to replacement or repair of Covered Items by these warranties, labor is not covered. Prior to return or repair of Covered Items, the customer must obtain a return goods authorization number from Pelican and at Pelican's option, return the Covered Items freight prepaid. Any Covered Item repaired or replaced under these warranties will be returned prepaid standard freight to the original point of shipment. Expedited freight options are available at customer expense.

No warranty is made with respect to defects or damaged due to neglect, misuse, alterations, accident, misapplication, physical damage, or damaged caused by fire, acts of God, or freezing. These warranties apply only to the original registered owner so long as the owner owns the home in which the unit was originally installed. Customer must register their system with Pelican within 90 days of purchase* in order to obtain a warranty. Warranty will discontinue after the unit is removed from the location where it was originally installed. Warranty begins on the date of delivery of product to the customer. Improper maintenance of system (i.e. not replacing filters or media) on time will be considered "neglect". Installation of any system on water conditions outside of or beyond the recommended specs of any system voids any warranty.

Pelican gives this warranty to the customer in lieu of all other warranties, express or implied, including without limitation any implied warranties of merchantability or fitness for a particular purpose or treatment of certain water and hereby expressly disclaims all other such warranties. Pelican's liability hereunder shall not exceed the cost of the product. Under no circumstances will Pelican be liable for any incidental or consequential damages or for any other loss, damage or expense of any kind, including loss of use, arising in connection with the installation or use or inability to use the Covered Items or any water treatment system the Covered Items are incorporated into. These warranties are governed by the laws of the state of Florida and may change at any time without notice.

*Failure by California and Quebec residents to complete the product registration form does not diminish their warranty rights.

**For all orders placed on or after June 3rd, 2011.

Manufacturer's Performance Guarantee

The Pelican PC600 Premium Whole House Water Filter is guaranteed to perform for 600,000 gallons or (5) years whichever comes first. The Pelican PC1000 Premium Whole House Water Filter is guaranteed to perform for 1,000,000 gallons or (5) years whichever comes first. The authorized dealers shall be responsible for the repair or replacement of defective media only, labor to replace the media is the responsibility of the purchaser.

Warranty Registration Form

Send in this Warranty Registration Form to validate your warranty or visit www.PelicanWaterTechnologies.com to complete warranty registration form.

Pelican Warranty Registration Form

Date Item(s) were Received:	Order ID#:	Model:
_____	_____	_____
Name: _____		
Address: _____		
City: _____	State: _____	Zip: _____

Send To:

Pelican Water Technologies
3060 Performance Circle, Suite 2
DeLand, FL 32724
Phone: 1-(877) 849-1635

Plumber's Information (optional)

We like to recommend good plumbers throughout the USA and if you were happy with your installer please give us their information so we can pass it on as a courtesy. Thank you for your time.

Name of Plumbing Company used to install system: _____

Phone #: (____)____-_____ of the Plumbing installer

!!IMPORTANT!

Do not use where water is microbiologically unsafe or with water of unknown quality without proper disinfection before or after the filter/softener system.

Pelican Water Systems